

Exhaust Fan for CDP/CDP-T 40-50-70

- EN External fan
- DE Externer Lüfter
- FR Ventilateur externe
- IT Ventilatore esterno
- PT Ventilador externo
- RU Внешний вентилятор
- DA Extern ventilator

Dantherm[®]

CONTROL YOUR CLIMATE

Part number, Art.-Nr.,
référence, numero di codice, ref.,
номер части, varenummer.

External fan, Externer Lüfter, Ventilateur externe, Ventilatore esterno, Ventilador externo, Внешний вентилятор, extern ventilator	
100	125
094339	094341

Connection, Anschluss,
raccordement, connessione,
ligação, подключение,
tilslutning.

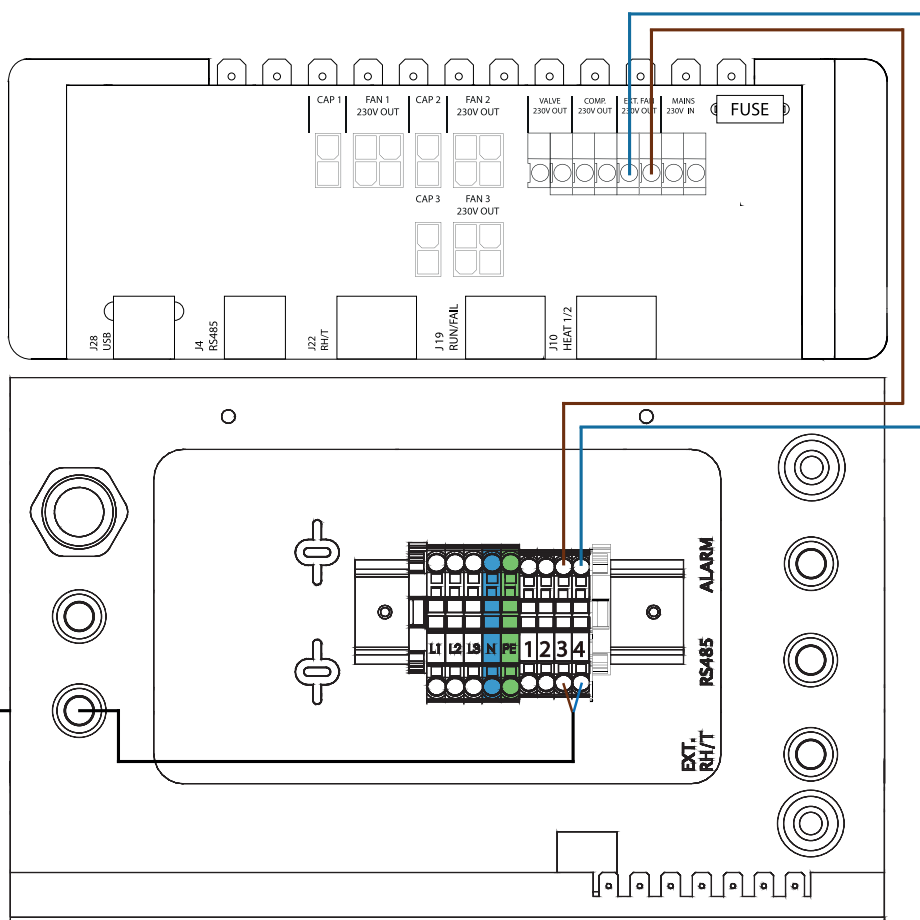

External fan, Externer Lüfter,
Ventilateur externe,
Ventilatore esterno, Ventilador
externo, Внешний вентилятор,
ekstern ventilator

Components,, Komponenten,
Компоненты, Composants,
componenti, Componentes,
komponenter.

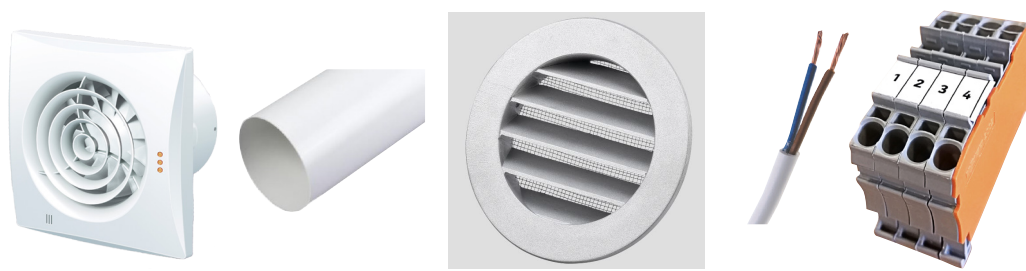

Dimensions, Abmessungen,
Dimensions, Dimensioni,
Dimensões, Габаритные
размеры, dimensioner.

	ØD	B	H	L	L1
Exhaust Fan 100	99	158	136	107	26
Exhaust Fan 125	124	182	158	91	27

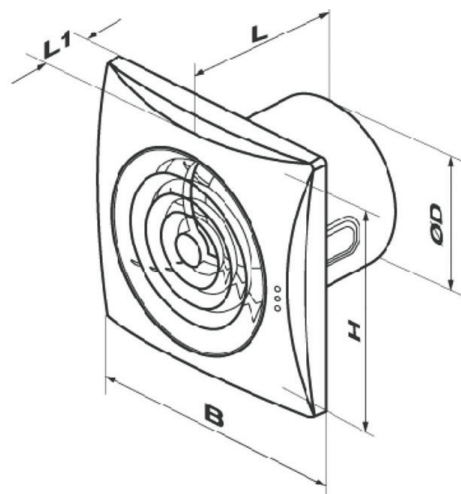

**Technical data, Technische Daten, Caractéristiques techniques,
Specifiche tecniche, Dados técnicos,
Технические характеристики, tekniske data**

External fan, Externer Lüfter, Ventilateur externe, Ventilatore esterno, Ventilador externo, Внешний вентилятор, ekstern ventilator		
	100	125
Capacity freeblowing, Kapazität. (freiblasend), Soufflage libre de capacité, capacità a bocca libera, Capacidade de sopro livre, Емкость свободное нагнетание, Kapacitet fritblæsende	97 m ³ /h	185 m ³ /h
Soundlevel, Geräuschpegel, niveau sonore, livello sonoro, nível de som, уровень звука, lydniveau	25 dB (A)	32 dB (A)
Power consumption, Energieverbrauch, Consommation d'énergie, Consumo di energia, Consumo de energia, потребляемая мощность, Energiforbrug	7,5 W	17 W
Power connection, Netzanschluss, Raccordement électrique, connessione di alimentazione, Conexão de alimentação, подключение к источнику тока, nettilslutning.	230 V / 50 Hz	
Housing material, Gehäusematerial, Matériau du boîtier materiale custodia, Material da caixa, материал корпуса, kabinetmateriale.	ABS plast (white, weiß, blanc, bianca, branco, белый, hvid)	
Bearing, Lager, Palier, cuscinetto, Rolamento, Подшипник, leje.	Ball bearing, Kugellager, Roulement à billes, cuscinetto a sfera, Rolamento de esferas	
IP rating, IP-Bewertung, Notation IP, Valutazione IP, Classificação IP, рейтинг IP, IP klassifikation	IP 45	



Remember to supply fresh air into the room.

Betrachten Sie die Lieferung von frischer Luft in den Raum.

Envisager la fourniture d'air frais dans la chambre.

Prendere in considerazione la fornitura di aria fresca nella stanza.

Considerare o fornecimento de ar fresco para o quarto.

Запомни рассмотреть возможность подачи свежего воздуха в помещение.

Husk tilførsel af frisk luft til rummet.

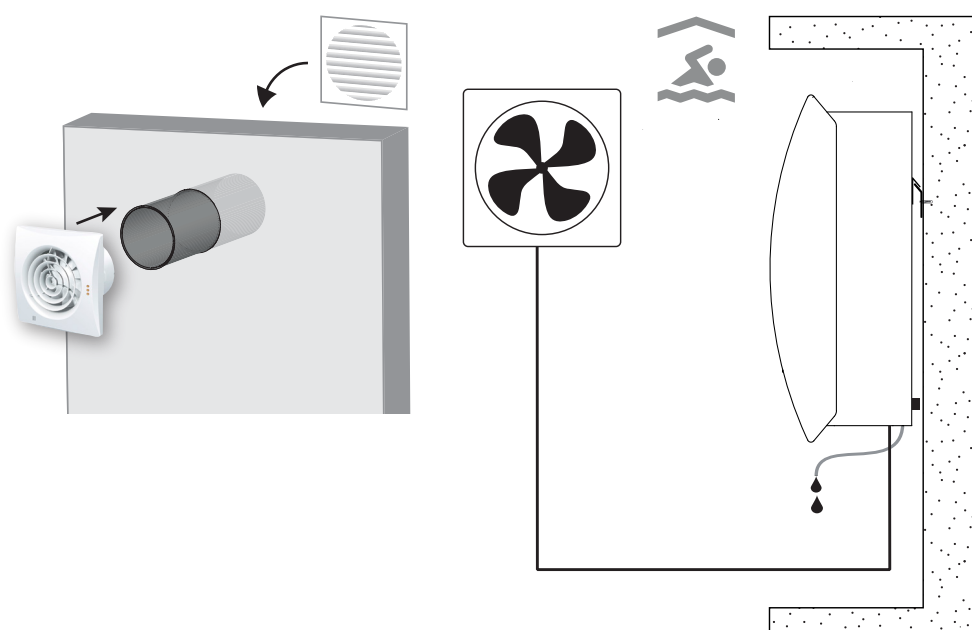

Dantherm Air Handling A/S

Marienlystvej 65
7800 Skive
Denmark

Phone +45 96 14 37 00
Fax +45 96 14 38 00

infodk@dantherm.com
www.dantherm.com

Dantherm AS

Postboks 4, 3101 Tønsberg
Norway
Besøksadresse: Løkkeåsvn. 263138
Skallestad

Phone +47 33 35 16 00
Fax +47 33 38 51 91

dantherm.no@dantherm.com
www.dantherm.com

Dantherm Air Handling AB

Fridhemsvägen 3
602 13 Norrköping
Sweden

Phone +46 (0) 111 930 40
Fax +46 (0) 121 133 70

infose@dantherm.com
www.dantherm.se

Dantherm Air Handling

Suite # 1009 Prism Tower
Business Bay
Dubai, UAE

Mobile +971 56 831 7466
Direct +45 60 23 55 29

frb@dantherm.com
www.dantherm.com

Dantherm Limited

12 Windmill Business Park
Windmill Road, Clevedon
North Somerset, BS21 6SR
England

Phone +44 (0)1275 87 68 51
Fax +44 (0)1275 34 30 86

infouk@dantherm.com
www.dantherm.co.uk

Dantherm Cooling A/S

4th Dobryninskiy Lane 8
Office C 11-01
119049 Moscow
Russia

Mobile +7 903 700 69 01
Phone +7 495 642 95 60
Fax +44 (0)1275 34 30 86

thj@dantherm.com
www.dantherm.com

Dantherm Cooling GmbH

Ziegler Str. 19
D-86199 Augsburg
Deutschland

Mobile +49 172 627 02 87
Direkt: +49 821 297 00 297
Fax +49 821 297 00 298

KW@dantherm.com
www.dantherm.com

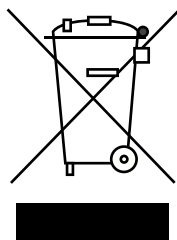

Dantherm can accept no responsibility for possible errors and changes.
Irrtümer und Änderungen vorbehalten.

Dantherm n'assume aucune responsabilité pour erreurs et modifications éventuelles.

Dantherm se exime de cualquier responsabilidad por errores y cambios realizados.

A Dantherm recusa qualquer responsabilidade relacionada com eventuais erros e alterações.

Компания Dantherm не принимает на себя ответственность за возможные ошибки и изменения в настоящем документе.